

The Basic Inductive Schema, Inductive Truisms, and the Research-Guiding Capacities of the Logic of Inductive Generalization*

Diderik Batens
Centre for Logic and Philosophy of Science
Universiteit Gent, Belgium
diderik.batens@ugent.be

May 3, 2004

Abstract

The aim of this paper is threefold. First, the sometimes slightly messy application of the conditional rule RC of the logic of inductive generalization is clarified by reducing this rule to a so-called basic schema BS. Next, some common truisms about inductive generalization are shown to be mistaken, but are also shown to be valid in special cases. Finally, and most importantly, it is shown that applications of the adaptive logic of inductive generalization to sets of data, possibly in the presence of background knowledge, invokes certain empirical tests and certain theoretically justified defeasible conjectures, which in a sensible way increase one's empirical and theoretical knowledge about a given domain.

1 The Problem

Some adaptive logics for inductive generalization were presented in [6]. These are based on Classical Logic (henceforth: **CL**) and include **IL**^r and **IL**^m, the basic logics of inductive generalization, as well as several logics for handling background knowledge. The paper extends [4] and presents the logics in the standard format from [2]. The programme behind [4] and [6], as well as behind the present paper, is to elaborate a *qualitative* account of inductive generalization. Such an account seems rather plausible, as humans have been applying inductive generalization (or, *pace* Popperians, something close to it) for many millennia and quite successfully so. Although several successful (local) quantitative methods were developed for inductive prediction, quantitative approaches to inductive *generalization* are tiresome as well as problematic, especially when it comes to devising a general (and generally justified) method.

The aim of the present paper is to solve a couple of open problems connected to **IL** (I use this name to refer to both aforementioned logics where the distinction does not matter) and to its relation with some two traditional truisms on

*Research for this paper was supported by subventions from Ghent University and from the Fund for Scientific Research – Flanders, and indirectly by the the Flemish Minister responsible for Science and Technology (contract BIL01/80).

inductive generalization. The first truism is that inductive generalizations are conjectures. **IL** is puzzling in this respect, as it determines a unique consequence set, $Cn_{\mathbf{IL}}(\Gamma)$, and hence a unique set of generalizations that can be derived from a set of data. The second is that a generalization can be upheld until falsified. This patently false from the viewpoint of **IL** because many generalizations that are not falsified by the set of data Γ do nevertheless not belong to $Cn_{\mathbf{IL}}(\Gamma)$.

We shall see why the truisms are wrong, but also where they may come from. A very important result of this study is that there are *different kinds of conjectures*, which have a different status and are justified along different roads. One kind of conjectures is justified by **IL** itself; these will be canned *derivable generalizations*. Another kind derives directly from (prioritized) background knowledge and will not be discussed in this paper. A third kind of conjectures are evoked by **IL**. Where certain inductive abnormalities (lack of uniformity) are connected, this very fact will incite the researcher to rely on theoretical insights or convictions to narrow down the connected abnormalities, and precisely this boils down to introducing hypothetical statements that answer questions evoked by the connected abnormalities. I shall reserve *conjectures* to refer to these. Finally, I shall discuss still another kind of ‘conjectures’, which will be called *guesses* (and may be somewhat wild).

A different matter, which is related to the invoked conjectures, is that applications of **IL** also evoke certain tests, which will augment the data that are relevant to the generalizations of the domain under study.

I shall outline the general plot behind adaptive logics of induction and introduce the logics \mathbf{IL}^r and \mathbf{IL}^m . In order to make the logic more transparent, I shall introduce a so-called basic schema BS which is contextually equivalent to the conditional rule RC of **IL**. Indeed, the application of RC may be somewhat messy, even if the rule itself is quite simple. Next I shall discuss the truisms. In my view, the most interesting part of these sections concerns the way in which applications of the adaptive logics of inductive generalization evoke tests as well as theoretical decisions, which will be expressed by prioritized conjectures.

2 The Plot

Let us start with an outline of the approach—see Figure 1. The outline is heavily simplified in several respects. A striking simplification concerns background knowledge. All background knowledge is obviously defeasible in that the data may contradict it. However, one should distinguish between several kinds of background theories and background generalizations. For example, some background generalizations are simply rejected when falsified, whereas the consequences of other falsified background generalizations (called pragmatic ones in [6]) will be retained whenever they are not themselves falsified—see [6] for details. As the interplay of **IL** with background knowledge is not essential for the present paper, the outline lists all background knowledge as a single set.

Where no logic is indicated, the consequence relation is that of **CL**. **Pi** refers to the suitable prioritized adaptive logic—there are several of them, each connected with a specific kind of background knowledge. The background knowledge BK is filtered by prioritized adaptive logics in view of the data. The thus selected background knowledge is added to the data; the joint sets deliver a set of consequences. Postponing for a moment the conjectures that interfere at

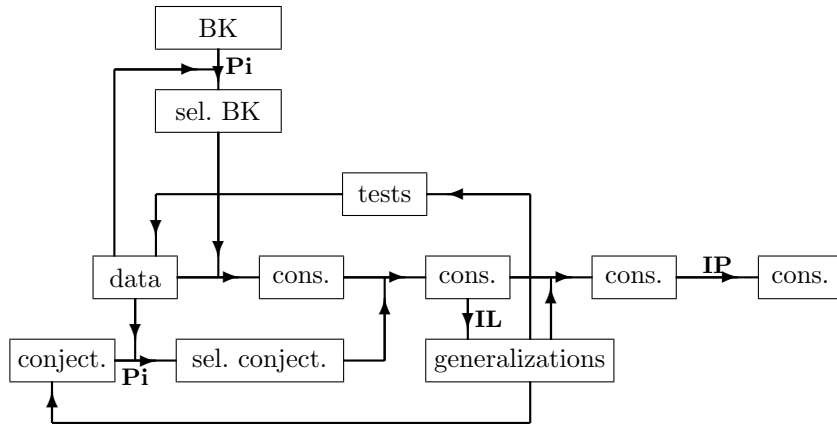

Figure 1: Inductive Cycles

this point, those consequences lead to inductive generalizations which, joined to the consequences deliver further generalizations as well as inductive predictions. The same consequences also evoke certain (further) conjectures which, filtered by the data, deliver further inductive generalizations. The same consequences also provoke certain tests, which deliver new data. Finally, the logic **IP** leads from all this to ‘inductive predictions’—these are not consequences of a derivable generalization, but rely on a kind of majority rule. The logic **IP** will play no role in the rest of the present paper. This paper will mainly concentrate on **IL**, which is the main work-horse of the set-up, on the way in which conjectures and tests are suggested by the **IL**-consequences, and on the effects of the conjectures and the outcomes of tests. As **IP** will be out of the picture anyway, I shall use “inductive prediction” to refer to **CL**-consequences of the data together with the derived generalizations and the conjectures.

3 The Adaptive Logics \mathbf{IL}^r and \mathbf{IL}^m

An adaptive logic in the standard format from [2] is defined by three components. These provide it with a dynamic proof theory and a semantics, and warrant a set of properties, among which the soundness and completeness of the proof theory with respect to the semantics. Where \mathcal{L} be the standard predicative language, let $\exists A$ be the existential closure of A and let \mathcal{F}° be the set of purely functional formulas of \mathcal{L} , that is, formulas in which occur no quantifiers and no individual constants. For **IL** the three components are:

- (i) The (monotonic and compact) *lower limit logic*: **CL**.
- (ii) The *set of abnormalities*, which is a set of formulas characterized by a logical form: $\Omega = \{\exists A \wedge \exists \sim A \mid A \in \mathcal{F}^\circ\}$.
- (iii) The *adaptive strategy*, which specifies what it means to interpret the premises ‘as normally as possible’: the Reliability strategy for \mathbf{IL}^r ; the Minimal Abnormality strategy for \mathbf{IL}^m .

As before, I shall write **IL** when referring to common properties of the two adaptive logics of inductive generalization, \mathbf{IL}^r and \mathbf{IL}^m .

Remark that an abnormality is an absence of uniformity (in the sense of [9]). The *upper limit logic*, which declares all abnormalities logically false, is **UCL**, obtained by extending the lower limit logic **CL** with the axiom schema $\exists A \supset \forall A$.¹

I first characterize the adaptive logics syntactically. An annotated line consists of a line number, a formula, a justification and a *condition*. Where $\Delta \subset \Omega$ is a finite set, let $Dab(\Delta)$ denote the disjunction of the members of Δ (in some preferred order). Such a formula will be called a *Dab*-formula because it is a disjunction of abnormalities. The rules of inference, listed below, are determined by the standard format. Remember that **CL** is the lower limit logic of **IL**. The rules should be interpreted as follows. The premise rule Prem allows one to introduce any premise with an empty condition at any point in the proof. The unconditional rule RU states that, if A_1, \dots, A_n occur in the proof on the respective conditions $\Delta_1, \dots, \Delta_n$, and B is derivable from A_1, \dots, A_n by the lower limit logic **CL**, then one may add B on the condition $\Delta_1 \cup \dots \cup \Delta_n$. Analogously for the conditional rule RC, which is the only one that introduces new elements to the condition.

PREM	Where Γ is the premise set, if $A \in \Gamma$:	$\frac{\dots \quad \dots}{A \quad \emptyset}$
RU	If $A_1, \dots, A_n \vdash_{\mathbf{CL}} B$:	$\frac{\begin{array}{cc} A_1 & \Delta_1 \\ \dots & \dots \\ A_n & \Delta_n \end{array}}{B \quad \Delta_1 \cup \dots \cup \Delta_n}$
RC	If $A_1, \dots, A_n \vdash_{\mathbf{CL}} B \vee Dab(\Theta)$	$\frac{\begin{array}{cc} A_1 & \Delta_1 \\ \dots & \dots \\ A_n & \Delta_n \end{array}}{B \quad \Delta_1 \cup \dots \cup \Delta_n \cup \Theta}$

While the rules depend only on the lower limit logic and on the set of abnormalities, the chosen strategy determines the marking definition. The marking definition for the Reliability strategy and that for the Minimal abnormality each require some technicalities.

At any stage of the proof, zero or more *Dab*-formulas will be derived on the empty condition. Remark that these *Dab*-formulas are **CL**-consequences of Γ . $Dab(\Delta)$ is a *minimal Dab-formula* at a stage s of a proof if, at stage s , $Dab(\Delta)$ is derived on the empty condition and there is no $\Delta' \subset \Delta$ for which $Dab(\Delta')$ is derived on the empty condition. Let $Dab(\Delta_1), \dots, Dab(\Delta_n)$ be the minimal *Dab*-formulas that are derived at stage s . The set of unreliable abnormalities is then $U_s(\Gamma) = \Delta_1 \cup \dots \cup \Delta_n$. Let $\Phi_s^\circ(\Gamma)$ be the set of all sets that contain one disjunct out of each Δ_i ($1 \leq i \leq n$). Let $\Phi_s^*(\Gamma)$ contain, for any $\varphi \in \Phi_s^\circ(\Gamma)$, the set $Cn_{\mathbf{CL}}(\varphi) \cap \Omega$. Finally let $\Phi_s(\Gamma)$ contain those members of $\Phi_s^*(\Gamma)$ that are not proper supersets of a member of $\Phi_s^*(\Gamma)$.

¹The **UCL**-models are those **CL**-models in which the interpretation of any predicate of adicity n is either the empty set or the set of all n -tuples of members of the domain.

Definition 1 *Marking for \mathbf{IL}^r* : Line i is marked at stage s iff, where Δ is its condition, $\Delta \cap U_s(\Gamma) \neq \emptyset$.

Definition 2 *Marking for \mathbf{IL}^m* : Line i is marked at stage s iff, where A is the formula and Δ the condition of line i , (i) there is no $\varphi \in \Phi_s(\Gamma)$ such that $\varphi \cap \Delta = \emptyset$, or (ii) for some $\varphi \in \Phi_s(\Gamma)$, there is no line k that has A as its formula and has as its condition a Θ such that $\varphi \cap \Theta = \emptyset$.

Derivability is introduced by the three following definitions:

Definition 3 *A formula A is derived at stage s of a proof from Σ iff A is the formula of a non-marked line at stage s .*

Definition 4 *A is finally derived from Γ on line i of a proof at stage s iff (i) A is the formula of line i , (ii) line i is not marked at stage s , and (iii) any extension of the proof in which line i is marked may be further extended in such a way that line i is unmarked.*

Definition 5 $\Gamma \vdash A$ (A is finally derivable from Γ) iff A is finally derived on a line of a proof from Γ .

It is often useful to refer to the condition on which a formula is derivable at a stage. This is illustrated by the following lemma, which we shall need in the sequel. The proof proceeds by an obvious induction on the length of the proof.

Lemma 1 *Where \mathbf{AL} is an adaptive logic in standard format and \mathbf{LLL} is its lower limit logic, A is derivable on the condition Δ in a dynamic proof from Γ iff $\Gamma \vdash_{\mathbf{LLL}} A \vee Dab(\Delta)$.*

The intended application context of \mathbf{IL} concerns premise sets that contain data (singular statements) only. Of course background knowledge plays a role in nearly any inductive generalization, but background knowledge should be handled by different (prioritized) adaptive logics as explained in [6]. I also refer the reader to that paper for some examples of \mathbf{IL} -proofs; the only example in the present paper is in Section 9.

The semantics of \mathbf{IL}^r and \mathbf{IL}^m is given directly by the standard format and soundness and completeness are provable along the standard road. For each \mathbf{CL} -model M , we define $Ab(M) = \{A \in \Omega \mid M \models A\}$. Where $\Delta_1, \Delta_2, \dots$ are the subsets of Ω for which $Dab(\Delta_i)$ is a minimal Dab -consequence of Γ ,² $U(\Gamma) = \Delta_1 \cup \Delta_2 \cup \dots$.

A \mathbf{CL} -model M of Γ is an \mathbf{IL}^r -model of Γ iff $Ab(M) \subseteq U(\Gamma)$; $\Gamma \vDash_{\mathbf{IL}^r} A$ iff A is verified by all \mathbf{IL}^r -models of Γ . A \mathbf{CL} -model M of Γ is an \mathbf{IL}^m -model of Γ iff there is no \mathbf{CL} -model M' of Γ such that $Ab(M') \subset Ab(M)$; $\Gamma \vDash_{\mathbf{IL}^m} A$ iff A is verified by all \mathbf{IL}^m -models of Γ .

4 The Basic Schema

In inconsistency-adaptive logics the conditional rule RC is just like that for \mathbf{IL} , except that the lower limit logic is some paraconsistent logic, say \mathbf{CLuN} as in [1]:

²This simply means that all \mathbf{CL} -models of Γ verify $Dab(\Delta_i)$ but that, for every $\Theta \subset \Delta_i$, some models falsify $Dab(\Theta)$.

$$\text{RC} \quad \text{If } A_1, \dots, A_n \vdash_{\mathbf{CLuN}} B \vee Dab(\Theta) \quad \begin{array}{c} A_1 \quad \Delta_1 \\ \dots \quad \dots \\ A_n \quad \Delta_n \end{array} \\ \hline B \quad \Delta_1 \cup \dots \cup \Delta_n \cup \Theta$$

The standard negation (here \sim) is paraconsistent in \mathbf{CLuN} ($A \wedge \sim A$ is not logically false). Adding classical negation (here \neg) to \mathbf{CLuN} greatly simplifies the metatheoretic proofs and also enables one to obtain more transparent object-level proofs. For example, the rule RC can be replaced by the following rule, which I shall call the basic schema (for inconsistency-adaptive logics):

$$\text{BS} \quad \frac{\exists \sim A \vee B \quad \Delta}{\exists \neg A \vee B \quad \Delta \cup \{\exists(A \wedge \sim A)\}}$$

Remark that $\neg A$ is a strengthening of $\sim A$, whereas A is (equivalent to) the classical negation of $\neg A$.

It is useful to see what is behind BS. That $\exists \sim A \vee B$ is derivable on the condition Δ from a premise set Γ (see the premise line of BS) corresponds, as remarked before, to the fact that

$$\Gamma \vdash_{\mathbf{CLuN}} (\exists \sim A \vee B) \vee Dab(\Delta).$$

This is equivalent to each of the following

$$\begin{aligned} \Gamma \vdash_{\mathbf{CLuN}} (\exists(\neg A \vee \sim A) \vee B) \vee Dab(\Delta) \\ \Gamma \vdash_{\mathbf{CLuN}} (\exists((\neg A \vee \sim A) \wedge (\neg A \vee A)) \vee B) \vee Dab(\Delta) \\ \Gamma \vdash_{\mathbf{CLuN}} (\exists(\neg A \vee (A \wedge \sim A)) \vee B) \vee Dab(\Delta) \end{aligned}$$

and from the last follows:

$$\Gamma \vdash_{\mathbf{CLuN}} (\exists \neg A \vee \exists(A \wedge \sim A)) \vee B) \vee Dab(\Delta),$$

which is equivalent to

$$\Gamma \vdash_{\mathbf{CLuN}} (\exists \neg A \vee B) \vee Dab(\Delta \cup \{\exists(A \wedge \sim A)\}),$$

which means that $\exists \neg A \vee B$ is derivable from the premise set on the condition $\Delta \cup \{\exists(A \wedge \sim A)\}$, as the conclusion of BS states.

This basic schema is heuristically useful. The insight deriving from it moreover clarifies what is going on in inconsistency-adaptive logics: the paraconsistent negation of A is identified with the classical negation of A on the condition that $A \wedge \sim A$ is false on the premises.³

This suggests that it is worthwhile to consider the question whether it is possible to formulate a basic schema for \mathbf{IL} . The answer is positive, and here it is:

$$\text{BS} \quad \text{where } \exists A \wedge \exists \sim A \in \Omega: \quad \frac{\exists A \vee B \quad \Delta}{\forall A \vee B \quad \Delta \cup \{\exists A \wedge \exists \sim A\}}$$

³The wording is slightly more complicated in the predicative case, but I do not mention that one here as this is not a paper on inconsistency-adaptive logics.

Remember that the standard negation \sim is classical in **IL**. $\forall A$ is a strengthening of $\exists A$, whereas $\exists \sim A$ is (equivalent to) the classical negation of $\forall A$.

The proofs of the following lemma and theorem are instructive to clarify the status and function of BS in the logic **IL**.

Lemma 2 *BS is derivable from {PREM, RU, RC}.*

Proof. Suppose that $\exists A \vee B$ is derivable on the condition Δ in an **IL**-proof from the premise set Γ . In view of Lemma 1, the first statement of the following list holds true. Moreover, all statements in the list are equivalent.

$$\begin{aligned} \Gamma \vdash_{\mathbf{CL}} (\exists A \vee B) \vee Dab(\Delta) \\ \Gamma \vdash_{\mathbf{CL}} ((\forall A \vee \exists A) \vee B) \vee Dab(\Delta) \\ \Gamma \vdash_{\mathbf{CL}} (((\forall A \vee \exists A) \wedge (\forall A \vee \exists \sim A)) \vee B) \vee Dab(\Delta) \\ \Gamma \vdash_{\mathbf{CL}} ((\forall A \vee (\exists A \wedge \exists \sim A)) \vee B) \vee Dab(\Delta) \\ \Gamma \vdash_{\mathbf{CL}} (\forall A \vee B) \vee Dab(\Delta \cup \{\exists A \wedge \exists \sim A\}) \end{aligned}$$

In view of Lemma 1 the last statement entails that $\forall A \vee B$ is derivable by RC on the condition $\Delta \cup \{\exists A \wedge \exists \sim A\}$ in a proof from Γ . ■

Theorem 1 $\Gamma \vdash_{\{\text{PREM, RU, RC}\}} A$ iff $\Gamma \vdash_{\{\text{PREM, RU, BS}\}} A$.

Proof. The right–left direction is Lemma 2. For the left–right direction, suppose that B is derived on the condition $\{\exists A_1 \wedge \exists \sim A_1, \dots, \exists A_n \wedge \exists \sim A_n\}$ in a proof in terms of {PREM, RU, RC}. By Lemma 1,

$$\Gamma \vdash B \vee (\exists A_1 \wedge \exists \sim A_1) \vee \dots \vee (\exists A_n \wedge \exists \sim A_n). \quad (1)$$

Let Σ be the set of all formulas of the form $\forall \pm A_1 \wedge \dots \wedge \forall \pm A_n$ in which each \pm is either \sim or nothing.⁴ Remark that (1) is equivalent to

$$\Gamma \vdash \bigvee(\Sigma) \supset B. \quad (2)$$

Whence, in a proof in terms of {PREM, RU, BS}, one can obtain

$$i \quad \bigvee(\Sigma) \supset B \quad \text{RU} \quad \emptyset$$

And in such a proof one can always obtain

$$\begin{array}{llll} j^1 & \exists A_1 \vee \forall \sim A_1 & \text{RU} & \emptyset \\ j^2 & \forall A_1 \vee \forall \sim A_1 & \text{BS} & \{\exists A_1 \wedge \exists \sim A_1\} \\ \vdots & \vdots & \vdots & \vdots \\ j^{2n} & \exists A_n \vee \forall \sim A_n & \text{RU} & \emptyset \\ j^{2n+1} & \forall A_n \vee \forall \sim A_n & \text{BS} & \{\exists A_n \wedge \exists \sim A_n\} \\ j^{2n+2} & \bigvee(\Sigma) & j^2, j^4, \dots, j^{2n}; \text{RU} & \{\exists A_1 \wedge \exists \sim A_1, \dots, \exists A_n \wedge \exists \sim A_n\} \end{array}$$

and hence also

$$j^{2n+3} \quad B \quad i, j^{2n+2}; \text{RU} \quad \{\exists A_1 \wedge \exists \sim A_1, \dots, \exists A_n \wedge \exists \sim A_n\}$$

⁴The first \pm may be represent \sim while the second represents an empty string, etc.

■

This seems the best point to warn against the misleading symmetry of applications of BS. If $\Gamma \vdash_{\mathbf{CL}} \exists A$ one can derive $\forall A$ on the condition $(\exists A \wedge \exists \sim A)$ and if $\Gamma \vdash_{\mathbf{CL}} \exists \sim A$ one can derive $\forall \sim A$ on the condition $(\exists A \wedge \exists \sim A)$. For complex A , however, at best one of these derivations is sensible. Suppose indeed that A is $\forall x(Px \supset Qx)$ and that $\exists x \sim (Px \supset Qx)$, or equivalently $\exists x(Px \wedge \sim Qx)$, was derived on the condition \emptyset . It is not very sensible to derive from this the formula $\forall x(Px \wedge \sim Qx)$ on the condition $\{\exists(\sim Px \vee Qx) \wedge \exists \sim(\sim Px \vee Qx)\}$. Indeed, it is then advisable to derive $\forall xPx$ on the condition $\{\exists xPx \wedge \exists x \sim Px\}$, to derive $\forall \sim Qx$ on the condition $\{\exists xQx \wedge \exists x \sim Qx\}$, and next to derive $\forall x(Px \wedge \sim Qx)$ on the condition $\{\{\exists xPx \wedge \exists x \sim Px\}, \{\exists xQx \wedge \exists x \sim Qx\}\}$. As soon as new data lead to the derivation of, for example, $\exists xPx \wedge \exists x \sim Px$, the lines in which $\forall xPx$ and $\forall x(Px \wedge \sim Qx)$ are derived will be marked, as is desirable.

A further warning is required. The reader might have the impression from BS that $\forall A$ is derivable on the condition $\exists A \wedge \exists \sim A$ in a proof from Γ whenever $\forall A$ is derivable on *some* condition in a proof from Γ . That this is not the case is easily seen from the following premise set:

$$\Gamma = \{Pa \vee Qa, Pb \vee \sim Qb\}.$$

The generalization $\forall xPx$ may be derived from this premise set⁵ on the condition $\{\exists xQx \wedge \exists x \sim Qx, \exists xPx \wedge \exists x \sim Px\}$, but it is impossible to derive it on the condition $\{\exists xPx \wedge \exists x \sim Px\}$.

Incidentally, this example illustrates that, although BS neatly expresses the idea behind the conditional rule RC of \mathbf{IL} , the proofs in terms of {PREM, RU, BS} are sometimes less transparent than the proofs in terms of {PREM, RU, RC}.

1	$Pa \vee Qa$	PREM	\emptyset
2	$Pb \vee \sim Qb$	PREM	\emptyset
3	$\exists xQx \vee \exists xPx$	1; RU	\emptyset
4	$\exists xPx \vee \exists x \sim Qx$	2; RU	\emptyset
5	$\forall xQx \vee \exists xPx$	3; BS	$\{\exists xQx \wedge \exists x \sim Qx\}$
6	$\exists xPx$	4, 5; RU	$\{\exists xQx \wedge \exists x \sim Qx\}$
7	$\forall xPx$	6; BS	$\{\exists xQx \wedge \exists x \sim Qx, \exists xPx \wedge \exists x \sim Px\}$

Compare 3–7 to:

3	$\exists xPx \vee \exists xQx$	1; RU	\emptyset
4	$\exists xPx \vee \exists x \sim Qx$	2; RU	\emptyset
5	$\exists xPx$	3, 4; RC	$\{\exists xQx \wedge \exists x \sim Qx\}$
6	$\forall xPx$	5; RC	$\{\exists xQx \wedge \exists x \sim Qx, \exists xPx \wedge \exists x \sim Px\}$

5 Falsification, Co-Compatibility, and Uniformity

By a generalization I shall mean the universal closure of a purely functional formula—see [4, §3] for a justification of this restriction. A widespread truism

⁵Such premise sets are by no means anomalous or unusual. Often our observational criteria warrant only complex empirical data.

holds it that a generalization $\forall A$ is sustainable in view of a data set Γ iff (i) Γ entails an instance of $\forall A$ and (ii) does not falsify $\forall A$.

The last example of the previous section illustrates that (i) is not necessary for $\Gamma \vdash_{\mathbf{IL}} \forall A$. However, (i) and (ii) are also insufficient for $\Gamma \vdash_{\mathbf{IL}} \forall A$. This is easily seen if one considers ‘connected’ abnormalities, which occur if a minimal *Dab*-consequence of Γ has more than one disjunct. The matter is illustrated by the following set of data

$$\Gamma = \{Pa, \sim Pb, Qb, \sim Pc, \sim Qc, Qd\}$$

from which several instances of $\forall x(Px \supset Qx)$ are derivable and that does not falsify this generalization.

And yet $\forall x(Px \supset Qx)$ is not an **IL**-consequence of Γ . Suppose that the generalization is derived on the condition $\exists x(Px \supset Qx) \wedge \exists x \sim(Px \supset Qx)$ in line *i*. The formula

$$(\exists x(Px \supset Qx) \wedge \exists x \sim(Px \supset Qx)) \vee (\exists x(Px \supset \sim Qx) \wedge \exists x \sim(Px \supset \sim Qx))$$

is a minimal *Dab*-consequence of Γ and when it is derived, line *i* is marked.⁶

The situation may be repaired by adding (what philosophers of science call) a *positive instance* of $\forall x(Px \supset Qx)$. Indeed, it is easily seen that

$$\Gamma \cup \{Pe \wedge Qe\} \vdash_{\mathbf{CL}} \exists x(Px \supset \sim Qx) \wedge \exists x \sim(Px \supset \sim Qx)$$

and that $\forall x(Px \supset Qx)$ is **IL**-derivable from $\Gamma \cup \{Pe \wedge Qe\}$.

However, the presence of a positive instance does not in general warrant the derivability of a generalization. For example, Γ contains a positive instance of $\forall x(Qx \supset \sim Px)$, which is equivalent to $\forall x(Px \supset \sim Qx)$. Nevertheless $\forall x(Qx \supset \sim Px)$ is not **IL**-derivable from Γ . So the conclusion is that the presence of even a positive instance together with the absence of falsification is insufficient to derive a generalization.

What is the criterion behind **IL**? One might be tempted to think that it is co-compatibility, viz. that a generalization $\forall A$ is **IL**-derivable from Γ iff $\Delta \cup \{\forall A\}$ is compatible with Γ whenever the set of generalizations Δ is compatible with Γ . Co-compatibility seems a reasonable criterion, and quite few arguments connect it to final **IL**-derivability. Clearly all finally **IL**-derivable generalizations are jointly compatible with Γ —they are all true in the preferred **CL**-models of Γ . Next, if Γ contains an instance of each member of the set of generalizations $\{\forall A_1, \dots, \forall A_n\}$, then this set is incompatible with Γ iff $\Gamma \vdash_{\mathbf{CL}} (\exists A_1 \wedge \exists \sim A_1) \vee \dots \vee (\exists A_n \wedge \exists \sim A_n)$. Also, it is provable that $\forall A$ is not co-compatible with Γ if $(\exists A \wedge \exists \sim A) \vee (\exists B_1 \wedge \exists \sim B_1) \vee \dots \vee (\exists B_n \wedge \exists \sim B_n)$ is a minimal *Dab*-consequence of Γ .

It is easily seen from the last example from Section 4 that co-compatibility is *not* the criterion for final **IL**-derivability. Indeed, if $\Gamma = \{Pa \vee Qa, Pb \vee \sim Qb\}$, then both $\forall x Px$ and $\forall x \sim Px$ are compatible with Γ and the set containing both is not compatible with Γ , whence $\forall x Px$ is not co-compatible with Γ , but nevertheless $\Gamma \vdash_{\mathbf{IL}} \forall x Px$.

This brings us back to the original idea behind **IL**: the criterion for final **IL**-derivability is uniformity, or rather absence of inductive abnormality. This

⁶The generalization may be derived on different (related) conditions, but some of their members are disjuncts of a minimal *Dab*-consequence of Γ .

criterion is interpreted somewhat differently by the two strategies. Reliability requires that finally derived formulas should be reliable with respect to the minimal *Dab*-consequences of the premise set. Minimal Abnormality requires that the premise set be interpreted minimal abnormally; semantically: the selected models are the minimal abnormal **CL**-models of the premise set.

Of course, there are other useful criteria for deciding that a generalization is not finally **IL**-derivable from a premise set. A first and obvious criterion is that the generalization is falsified by the premises. A second criterion is connected abnormalities (which may be seen as a form of connected falsification), which was discussed in the present section. A special case of this criterion is lack of information. Consider any data set Γ in which the (unary) predicate S does not occur. As $\exists xSx \vee \exists x\sim Sx$ is derivable from Γ , $\forall xSx \vee \forall x\sim Sx$ can be derived on the condition $\{\exists xSx \wedge \exists x\sim Sx\}$ in a proof from Γ , and as this line cannot possibly be marked, $\forall xSx \vee \forall x\sim Sx$ is finally derivable from Γ . This is very reasonable. As Γ provides no information about S , we suppose S to display no abnormalities. However, neither $\forall xSx$ nor $\forall x\sim Sx$ is finally derivable from this Γ , as desired.

6 Evoked Tests

We have seen that neither $\forall x(Px \supset Qx)$ nor $\forall x(Px \supset \sim Qx)$ are finally **IL**-derivable from the premise set

$$\Gamma = \{Pa, \sim Pb, Qb, \sim Pc, \sim Qc, Qd\}.$$

because

$$(\exists x(Px \supset Qx) \wedge \exists x\sim(Px \supset Qx)) \vee (\exists x(Px \supset \sim Qx) \wedge \exists x\sim(Px \supset \sim Qx)) \quad (3)$$

is a minimal *Dab*-consequence of Γ . This disjunction evokes the question:⁷ Which of the two abnormalities is the case? And this question implies: $\{Qa, \sim Qa\}$ (is Qa the case or is $\sim Qa$ the case?).

If empirical (observational or experimental) means are available to answer this question, the question may be called a *test*. Depending on its outcome, the main question (whether the first or the second disjunct of (3) is the case) is at once settled. Whichever the outcome, the effect on the **IL**-consequences of the thus extended premise set is dramatic. If the answer is Qa , the answer to the main question is

$$\exists x(Px \supset \sim Qx) \wedge \exists x\sim(Px \supset \sim Qx). \quad (4)$$

When Qa is added as a new premise and (4) is derived, (3) is not any more a minimal *Dab*-formula. Hence $\forall x(Px \supset \sim Qx)$ is falsified and $\forall x(Px \supset Qx)$ is finally derivable from the premises. If the answer is $\sim Qa$, the first disjunct of (3) is derivable (and is the answer to the main question), $\forall x(Px \supset Qx)$ is falsified and $\forall x(Px \supset \sim Qx)$ is finally derivable from the premises.

The two generalizations considered in the previous example are closely connected: the *implicantia* are identical and the *implicata* are contradictories.

⁷I use question evocation in the technical sense of [13] and [12]. Similarly for implied questions—see later in the text.

There need not be such a connection between the disjuncts of *Dab*-formulas, as appears from the following example.

$$\Gamma = \{Pa, Qa, \sim Ra, \sim Pb, \sim Qb, Rb, Pc, Rc, Qd, \sim Pe\}$$

Both $\forall x(Px \supset Qx)$ and $\forall x(Rx \supset \sim Qx)$ are compatible with Γ , but neither of them is **IL**-derivable because

$$(\exists x(Px \supset Qx) \wedge \exists x \sim(Px \supset Qx)) \vee (\exists x(Rx \supset \sim Qx) \wedge \exists x \sim(Rx \supset \sim Qx))$$

is a minimal *Dab*-consequence of Γ .

By the same reasoning as in the previous example, Γ evokes the question which of the two disjuncts of the *Dab*-formula is true, and this question implies $? \{Qc, \sim Qc\}$. If the derived question is a test (can be answered by empirical means), each direct answer will falsify one of the generalizations and will make the other generalization **IL**-derivable.

The outcomes of the considered tests make a one disjunct *Dab*-formula **CL**-derivable, falsify one of the considered generalizations, and hence make the other generalization finally **IL**-derivable from Γ . If the minimal *Dab*-formula counts more disjuncts, several tests may (usually) be needed, but the effect will be the same. So the tests are directed towards increasing the derivable generalizations; they are generative (in a weak sense, however: as discussed here, they do not lead to the development of new concepts).

Obviously, the generalization that becomes finally derivable as an effect of a test may later be falsified by new data. And nothing prevents one from ‘trying to falsify’ the generalization by performing further tests. However, it is important to realize that the function of such tests is different from the function of the considered test $? \{Qc, \sim Qc\}$. Suppose that, in the last example, the test led to the final derivability (from the extended Γ) of $\forall x(Px \supset Qx)$. Attempts to falsify this generalization may establish its falsehood, but need not have a generative effect.

Two further comments seem useful in connection with the last example. The first concerns the derivability of a weakening of a falsified generalization. Suppose again that the test $? \{Qc, \sim Qc\}$ was performed and led to the answer Qc . As we have seen $\forall x(Rx \supset \sim Qx)$ is then falsified. However, $\forall x((Rx \wedge \sim Px) \supset \sim Qx)$ is still **IL**-derivable from the extended premise set. The idea was of course already present in [10]: if a generalization⁸ is falsified, one moves to a next most interesting (most falsifiable) generalization.

The second comment is intended to avoid a possible misunderstanding. The test that were discussed before are directed at deciding which disjunct of a minimal *Dab*-formula holds true, and thus at generating new generalizations (in making them derivable). This may lead some readers to the impression that the test evoked by **IL** are directed at keeping the gathering of new empirical evidence minimal; a poor data set, they might think, warrants that many generalizations are derivable. This impression is mistaken. First of all, the **IL**-consequences of a

⁸Popper would of course have preferred that this statement be phrased about theories, but the application of **IL** with respect to theories cannot be discussed in the present paper. By present lights, two main issues are involved: (i) a theory should organize a domain of knowledge in a concise and coherent way, and, more importantly, (ii) every derivable generalization evokes an explanation question. The answer to the explanation question will nearly always require the development of new concepts, and it is this point which cannot be discussed here.

premise set evoke other tests as well—see below. Next, if no data about certain predicates or about the connection between certain predicates are available, no generalization will be **IL**-derivable about those predicates or about their connection. The first example of this section illustrates that very well. Thus **IL** evokes questions, and hopefully tests, about undocumented predicates and undocumented connections between predicates. It is correct that, in doing so, **IL** follows a certain policy, viz. to locate abnormalities and thus to eliminate other suspected abnormalities. But this is by no means a bad policy, even from a Popperian point of view. The policy comes down to an attempt to *reduce known problems*: one knows that either $\forall x(Px \supset Qx)$ or $\forall x(Rx \supset \sim Qx)$ is problematic, and it is possible to perform a test that identifies one of them as problematic. In other words, the evoked tests are bound to successfully falsify certain generalizations. Even for those who consider falsification to be the path of science, it is sensible to perform first those tests that are bound to be successful falsifiers.

Let us now consider another kind of test that is evoked by **IL**. Consider the premise set (from Section 4)

$$\Gamma = \{Pa \vee Qa, Pb \vee \sim Qb\}$$

from which follows

$$\exists xPx \vee (\exists xQx \wedge \exists x\sim Qx)$$

and hence also

$$\forall xPx \vee ((\exists xQx \wedge \exists x\sim Qx) \vee (\exists xPx \wedge \exists x\sim Px)), \quad (5)$$

whence $\forall xPx$ is derivable on the condition $(\exists xQx \wedge \exists x\sim Qx) \vee (\exists xPx \wedge \exists x\sim Px)$ in a proof from Γ .

Incidentally, allow me to stress that such premise sets are by no means anomalous or unusual. Often our observational criteria warrant only complex empirical data.

Remark that (5) evokes the following question

$$?\{\forall xPx, \exists xQx \wedge \exists x\sim Qx, \exists xPx \wedge \exists x\sim Px\}$$

and that this (main) question entails each of $?\{\forall xPx, \sim\forall xPx\}$, $?\{\exists xQx \wedge \exists x\sim Qx, \sim(\exists xQx \wedge \exists x\sim Qx)\}$ and $?\{\exists xPx \wedge \exists x\sim Px, \sim(\exists xPx \wedge \exists x\sim Px)\}$. This means, for example, that questions about the *P*-hood of arbitrary objects are derivable.

Most often, (5) will not occur in the proof. What will occur is the formula $\forall xPx$ derived on the condition $(\exists xQx \wedge \exists x\sim Qx) \vee (\exists xPx \wedge \exists x\sim Px)$. However, this is an *implicit disjunction*, as the formula is derivable on the condition just in case (5) is derivable from the premise set (see Lemma 1).

In view of the data, the main question will lead (in one or more steps) to such questions as $?\{Pa, Qa\}$, $?\{Pb, \sim Qb\}$, $?\{Pa, \sim Pa\}$, etc. If the questions can be answered by empirical means, it will depend on the outcomes of the tests which further questions are evoked.

Where, in the earlier examples, the main questions are evoked directly by the presence of a disjunction of abnormalities in the proof, the present main question is evoked by a disjunction that is implicitly present, viz. in the form of a formula with a non-empty condition. Where, in the earlier examples a test

led necessarily to a falsification of one of the generalizations involved, this is not the case for the tests that are possibly derived from the main question of the last example.

There is a further important distinction between the previous examples and the present one. In order to establish that $\forall xPx$ is finally \mathbf{IL}^r -derived from the premise set Γ (on the line in which it is derived on the aforementioned condition), it is sufficient to establish that neither $\exists xQx \wedge \exists x\sim Qx$ nor $\exists xPx \wedge \exists x\sim Px$ is a disjunct of a minimal *Dab*-consequence of Γ .⁹

Remark that we are here dealing with a different question than before and that the question is evoked by a different disjunction, viz. the metalinguistic disjunction: either at least one of $\{\exists xQx \wedge \exists x\sim Qx, \exists xPx \wedge \exists x\sim Px\}$ is unreliable (is a member of $U(\Gamma)$) or $\forall A$ is finally derivable from Γ .

To show that both abnormalities are reliable with respect to Γ is possible by the computational approach to adaptive logics presented, for example, in [3].¹⁰ I cannot discuss the matter in the present paper, but the idea is that, in order to establish that a consequence derived on a non-empty condition Δ has been finally derived, one has to show that $Dab(\Delta)$ is not \mathbf{CL} -derivable from the premises. This is warranted if the procedure stops without the $Dab(\Delta)$ being derived, or if the disjunction is derived on a Θ and the procedure leads to a derivation of $Dab(\Theta)$ on the empty condition.

Before closing this section, a further point requires attention. It is one thing that tests are evoked, it is a different thing which tests are actually performed. The latter will partly depend on economic considerations, but I have a different point in mind. Independently of the premises, a researcher may have certain reasons to consider some generalization as plausible or implausible—such reasons are considered in the next section. If, in the last example, the researcher considers $\forall xPx$ implausible, this will provide a good reason to perform those tests that are likely to falsify the generalization.

7 Evoked Conjectures – the Idea

Not all questions can be answered by empirical means. The matter is related to the fact that the conclusion drawn from tests depends partly on certain theoretical assumptions. This problem strikingly surfaces when ‘theoretical predicates’ occur in the generalizations, or, more generally, when certain questions cannot be answered by empirical means.

Suppose that a *Dab*-formula

$$(\exists A_1 \wedge \exists \sim A_1) \vee \dots \vee (\exists A_n \wedge \exists \sim A_n)$$

was derived and that it cannot be (further) reduced by tests, or that the tests to reduce the *Dab*-formula are judged too expensive. The premises still evoke the question $\{(\exists A_1 \wedge \exists \sim A_1), \dots, (\exists A_n \wedge \exists \sim A_n)\}$.

At this point a researcher may have reasons to consider one of the abnormalities as true, thus freeing the other abnormalities from suspicion. Alternatively, the researcher may have a reason to conjecture that one of the generalizations

⁹The situation is slightly more complicated but similar for \mathbf{IL}^m .

¹⁰In that paper, the approach is discussed for inconsistency-adaptive logics, but it can easily be transferred to \mathbf{IL} .

$\forall A_i$ is true. Such a conjecture obviously contradicts the corresponding abnormality, in that $\forall A_i \vdash_{\mathbf{CL}} \sim(\exists A_i \wedge \exists \sim A_i)$, and hence reduces the *Dab*-formula to a shorter one.

The reasons mentioned in the previous paragraph may be of different kinds. It may happen that some information is originally not seen as relevant for solving a certain problem, but turns out relevant later. The researcher may be interested in a certain set of generalizations, say delineated in terms of a set of predicates, but as the derivation proceeds, find out that knowledge in terms of other predicates is indeed relevant. In such cases, new premises may be brought in. This boils down to the fact that the premise set Γ is replaced by a superset Γ' .

Two other kinds of reasons are more interesting at this point. First of all, the researcher may rely on personal constraints to blame a certain abnormality rather than the others, or to consider one of the connected generalizations, $\forall A_1, \dots, \forall A_n$, as the most plausible conjecture. Also, a careful study of the data and the *Dab*-formula in relation with theories from other domains, may provide a reason to make a choice between the abnormalities or between the connected generalizations. For example, even if the data do not falsify that a person's character is dependent on his or her blood group, such a dependency seems implausible because one's character is apparently a result of one's previous experiences and social interactions and not of some physiological properties.

What is going on here is that one stumbles upon a problem—Which disjunct or disjuncts of the *Dab*-formula are likely to be true or false?—and that this problem may be solved, or partially solved, outside the context in which one is deriving generalizations and ensuing predictions. The problem may be solvable by available knowledge that was originally not seen as relevant, or by a certain conjecture that relies on the researcher's views or that is arrived at by considering the involved abnormalities and generalizations in relation to other knowledge. The kind of moves we are considering can be seen as ways to *narrow down suspicion* in premise sets that display abnormalities (in that *Dab*-formulas are derivable from them).

Inductive generalizations that are derived by **IL** are conjectures in the sense that new evidence may falsify them. The abnormalities or generalizations introduced in order to narrow down suspicion are conjectures of a different kind. The data in themselves do not provide reasons to accept them; they are introduced for different reasons, which are related to the researcher's theoretical insights and world view. Henceforth I shall reserve “conjecture” for the latter kind (as I implicitly did in some previous passages as well).

We have seen that conjectures are introduced in order to narrow down the suspicion that is revealed by a minimal *Dab*-formula and pertains to all disjuncts of the formula. Given the specific form of the question, viz. $\{(\exists A_1 \wedge \exists \sim A_1), \dots, (\exists A_n \wedge \exists \sim A_n)\}$, there seem to be two candidates for conjectures: $\exists A_i \wedge \exists \sim A_i$ and $\sim(\exists A_i \wedge \exists \sim A_i)$. A little reflection reveals that the second form is the right one. Suppose indeed that one introduces the conjecture $\exists A_1 \wedge \exists \sim A_1$, but that new data become available and that $\exists A_2 \wedge \exists \sim A_2$ is derived from them. If the conjecture had not been introduced, the new data would free all $\exists A_i \wedge \exists \sim A_i$ ($1 \leq i \leq n$; $i \neq 2$) from suspicion, including $\exists A_1 \wedge \exists \sim A_1$. But if the conjecture $\exists A_1 \wedge \exists \sim A_1$ was introduced, no new data can possibly free it from being suspect. So if conjectures have the form $\exists A_i \wedge \exists \sim A_i$, they introduce a problem rather than solving one.

Unlike the premises, including those that were not originally seen as relevant, conjectures have to be introduced in a *defeasible* way. Suppose indeed that one simply adds to the premises the conjecture $\sim(\exists x(Px \supset Qx) \wedge \exists x\sim(Px \supset Qx))$, which is equivalent to $\forall x(Px \supset Qx) \vee \forall x(Px \wedge \sim Qx)$. New data (or even the old ones) may falsify both generalizations,¹¹ and the result would be a trivial premise set. So conjectures will be introduced in a defeasible way, that is, with a certain plausibility which does not make them immune for new data.¹² Remark that the difficulty cannot arise in connection with generalizations that are derived by **IL** from the data. If the premise set is extended and a derived generalization is falsified, the generalization is simply not be derivable any more from that point on—the line at which it is derived will be marked from that stage on as an effect of the marking definition. The technicalities concerning the defeasible introduction of conjectures will be discussed in the next section.

Having provided a researcher with the possibility to introduce defeasible conjectures, a further point still has to be brought up. A conjecture is clearly introduced because it is plausible (for reasons that do not depend on the data). Plausibility clearly comes in degrees; some conjectures may be considered as more plausible than others. In the subsequent section, I shall write $\diamond\sim(\exists A \wedge \exists\sim A)$ for a very plausible conjecture $\sim(\exists A \wedge \exists\sim A)$, $\diamond\diamond\sim(\exists A \wedge \exists\sim A)$ for a somewhat less plausible one, and so on. For the sake of generality, I shall abbreviate $\sim(\exists A \wedge \exists\sim A)$ preceded by i diamonds as $\diamond^i\sim(\exists A \wedge \exists\sim A)$, and this will express a higher plausibility (or priority or what have you) as i is smaller.

8 Evoked Conjectures – the Logic

I shall handle conjectures by combining the adaptive logics \mathbf{IL}^r and \mathbf{IL}^r with the adaptive logics \mathbf{T}^{sr} and \mathbf{T}^{sm} from [8]. In the present paper, the latter will handle prioritized premises of the form $\diamond^i\sim(\exists A \wedge \exists\sim A)$. Each of \mathbf{T}^{sr} and \mathbf{T}^{sm} may be seen as an infinite sequence of adaptive logics that all have the same structure—the first member suitably handles premises of the form $\diamond A$, the second premises of the form $\diamond^2 A$, etc. This is why the prioritized adaptive logic, if phrased as a single system, has a *sequence* of sets of abnormalities.

The lower limit logic will be called **T**—it is a particular predicative extension of the propositional modal logic **T**. Let \mathcal{L}^M be the result of extending \mathcal{L} with the modalities in the standard way. The pseudo-language \mathcal{L}^{M+} is obtained by extending \mathcal{L}^M with a set of pseudo-constants \mathcal{O} , which has at least the cardinality of the largest model one wants to consider. The function of \mathcal{O} is to simplify the clauses for the quantifiers; it is not specific for modal logic—see, for example, the semantics for the non-modal **P** in [7].

A **T**-model M is a quintuple $\langle W, w_0, R, D, v \rangle$ in which W is a set of worlds, $w_0 \in W$ the real world, R a binary relation on W , D a non-empty set and v an assignment function. The accessibility relation R is reflexive. The assignment function v is defined by:

¹¹If the premises consist of data only, it is decidable whether the old data falsify a generalization. The matter becomes more difficult, however, in the presence of background knowledge (see [6]) or conjectures.

¹²This highlights in a different way the problem that would arise if conjectures of the form $\exists A \wedge \exists\sim A$ were allowed even with a certain plausibility: no possible extension of the data set could possibly falsify them, and hence we would be stuck with them forever.

- C1.1 $v : \mathcal{S} \times W \mapsto \{0, 1\}$
C1.2 $v : (\mathcal{C} \cup \mathcal{O}) \times W \mapsto D$
C1.3 $v : \mathcal{P}^r \times W \mapsto \wp(D^r)$ (the power set of the r -th Cartesian product of D)

The valuation function $v_M : \mathcal{W}^{M+} \times W \mapsto \{0, 1\}$, determined by the model M is defined by:

- C2.1 where $A \in \mathcal{S}$, $v_M(A, w) = v(A, w)$
C2.2 $v_M(\pi^r \alpha_1 \dots \alpha_r, w) = 1$ iff $\langle v(\alpha_1, w), \dots, v(\alpha_r, w) \rangle \in v(\pi^r, w)$
C2.3 $v_M(\alpha = \beta, w) = 1$ iff $v(\alpha, w) = v(\beta, w)$
C2.4 $v_M(\sim A, w) = 1$ iff $v_M(A, w) = 0$
C2.5 $v_M(A \vee B, w) = 1$ iff $v_M(A, w) = 1$ or $v_M(B, w) = 1$
C2.6 $v_M(\exists \alpha A(\alpha), w) = 1$ iff $v_M(A(\beta), w) = 1$ for at least one $\beta \in \mathcal{C} \cup \mathcal{O}$
C2.7 $v_M(\diamond A, w) = 1$ iff $v_M(A, w') = 1$ for at least one w' such that Rww' .

The other logical symbols are defined in the usual way. A \mathbf{T} -model M verifies $A \in \mathcal{W}^M$ iff $v_M(A, w_0) = 1$. A is \mathbf{T} -valid iff it is verified by all \mathbf{T} -models.

It may be helpful to mention that the semantics may be rephrased in terms of a function d that assigns to each $w \in W$ its domain $d(w) = \{v(\alpha, w) \mid \alpha \in \mathcal{C} \cup \mathcal{O}\}$. If this is done, C1.3 is equivalent to “ $v : \mathcal{P}^r \times W \mapsto \wp((d(w))^r)$ ”. Remark also that the value of modal predicative expressions depends on the values of the pseudo-constants and constants, and not on the objects of the domain. Thus the value of $v_M(\diamond Pa, w)$ is determined by the values of $v(a, w')$ and $v(P, w')$ for those w' for which Rww' . As a result, the Barcan formula is \mathbf{T} -valid. See [8] for the possibility to rephrase the semantics as a counterpart semantics.

Consider an adaptive logic defined by lower limit logic \mathbf{T} , the set of abnormalities $\Omega^1 = \{(\exists A \wedge \exists \sim A) \wedge \diamond \sim (\exists A \wedge \exists \sim A) \mid A \in \mathcal{F}^\circ\}$ and either the Reliability strategy or the minimal Abnormality strategy. This logic interprets a set of premises as normal as possible with respect to the specific abnormalities. Consider, for example, a premise set comprising non-modal premises together with a single modal premise $\diamond \sim (\exists A \wedge \exists \sim A)$. The adaptive models of the premise set will be those that verify $\sim (\exists A \wedge \exists \sim A)$ provided there are such models. Indeed, all other models verify the abnormality $(\exists A \wedge \exists \sim A) \wedge \diamond \sim (\exists A \wedge \exists \sim A)$.

Next consider a sequence of adaptive logics, $\langle \mathbf{A}_1, \mathbf{A}_2, \dots \rangle$ each of which is defined by the lower limit logic \mathbf{T} , a same strategy, Reliability or Minimal Abnormality, and the following sets of abnormalities: $\Omega^1 = \{(\exists A \wedge \exists \sim A) \wedge \diamond \sim (\exists A \wedge \exists \sim A) \mid A \in \mathcal{F}^\circ\}$ for the first logic, \mathbf{A}_1 , $\Omega^2 = \{(\exists A \wedge \exists \sim A) \wedge \diamond \diamond \sim (\exists A \wedge \exists \sim A) \mid A \in \mathcal{F}^\circ\}$ for the second logic, \mathbf{A}_2 , etc. In the previous section I introduced the convention that $\diamond A$ is seen as expressing a stronger priority than $\diamond \diamond B$, etc.¹³ So, where the most complex modality occurring in the premise set is \diamond^n ,¹⁴ we want to interpret the premise set as follows:

$$Cn_{\mathbf{A}_n}(Cn_{\mathbf{A}_{n-1}}(\dots(Cn_{\mathbf{A}_1}(\Gamma))\dots)) \quad (6)$$

This looks somewhat frightening from a computational point of view, but actually it is not. It is possible to combine the sequence of adaptive logics $\langle \mathbf{A}_1, \mathbf{A}_2, \dots \rangle$ into a single *combined* adaptive logic (see [2, §3]) in such a way

¹³This agrees with the modal logic as $\diamond A \vdash_{\mathbf{T}} \diamond \diamond A$ but $\diamond \diamond A \not\vdash_{\mathbf{T}} \diamond A$.

¹⁴The case where the premise set contains some $\diamond^i A$ for all $i \in \mathbb{N}$ is obviously unrealistic with respect to the intended applications. This case is commented upon at the end of Section 3 of [5].

that the conditional rules¹⁵ of all \mathbf{A}_i can be applied at any point in the proof. The only effect of the combination is on the marking definition: one first marks in view of abnormalities of \mathbf{A}_1 , next in view of abnormalities of \mathbf{A}_2 , etc.

I shall now describe the prioritized adaptive logics \mathbf{T}^{sr} and \mathbf{T}^{sm} . The lower limit logic is \mathbf{T} , the sets of abnormalities are $\Omega^i = \{(\exists A \wedge \exists \sim A) \wedge \diamond^i \sim (\exists A \wedge \exists \sim A) \mid A \in \mathcal{F}\}$ ($i \geq 1$), and the strategy is Reliability for \mathbf{T}^{sr} and Minimal Abnormality for \mathbf{T}^{sm} . Incidentally, the upper limit logic is **Triv** (**CL** with modalities devoid of meaning).

Let $Dab^i(\Delta)$ abbreviate the disjunction (in some preferred order) of the members of $\Delta \in \Omega^i$ — $Dab^i(\Delta)$ is a meaningless expression if $\Delta \notin \Omega^i$; so, whenever I write $Dab^i(\Delta)$, I mean a $\Delta \in \Omega^i$.

$Dab^i(\Delta)$ is a minimal Dab^i -formula at a stage s of a proof iff, at stage s , (i) there is an unmarked line that has $Dab^i(\Delta)$ as its formula and a $\Theta \subseteq \Omega^1 \cup \dots \cup \Omega^{i-1}$ as its condition, and (ii) there is no $\Delta' \subset \Delta$ such that $Dab^i(\Delta')$ is the formula of an unmarked line that has a $\Theta \subseteq \Omega^1 \cup \dots \cup \Omega^{i-1}$ as its condition. The inference rules are exactly as in Section 3 except that **CL** is replaced by \mathbf{T} and that $Dab(\Theta)$ has to be replaced by $Dab^i(\Theta)$. Here they are:

PREM	Where Γ is the premise set, if $A \in \Gamma$:	$\frac{\dots \quad \dots}{A \quad \emptyset}$
RU	If $A_1, \dots, A_n \vdash_{\mathbf{T}} B$:	$\frac{\begin{array}{c} A_1 \quad \Delta_1 \\ \dots \quad \dots \\ A_n \quad \Delta_n \end{array}}{B \quad \Delta_1 \cup \dots \cup \Delta_n}$
RC	If $A_1, \dots, A_n \vdash_{\mathbf{T}} B \vee Dab^i(\Theta)$	$\frac{\begin{array}{c} A_1 \quad \Delta_1 \\ \dots \quad \dots \\ A_n \quad \Delta_n \end{array}}{B \quad \Delta_1 \cup \dots \cup \Delta_n \cup \Theta}$

Let $U_s^i(\Gamma)$ be defined as $U_s(\Gamma)$, but in terms of minimal Dab^i -formulas at stage s of a proof. Let $\Phi_s^i(\Gamma)$ be defined as $\Phi_s(\Gamma)$, but in terms of minimal Dab^i -formulas at stage s of a proof.

The Marking definitions are as in Section 3 except that they should be applied starting from level 1 abnormalities. To avoid confusion, I spell them out:

Definition 6 *Marking for Reliability (\mathbf{T}^{sr}) starting from $i = 1$: A line is marked at stage s iff, where Δ is its condition, $\Delta \cap U_s^i(\Gamma) \neq \emptyset$.*

Definition 7 *Marking for Minimal Abnormality (\mathbf{T}^{sm}) starting from $i = 1$: A line is marked at stage s iff, where A is the second element and Δ the fifth element of the line, (i) there is no $\varphi \in \Phi_s^i(\Gamma)$ such that $\varphi \cap \Delta = \emptyset$, or (ii) for some $\varphi \in \Phi_s^i(\Gamma)$, there is no line at which A is derived on a condition Θ for which $\varphi \cap \Theta = \emptyset$.*

¹⁵The premise rule and the unconditional rule are identical for all the adaptive logics in the sequence.

Final derivability is defined by Definition 5 (which relies on Definitions 3 and 4).

Turning to the semantics, I first recall that n is the largest i for which \diamond^i occurs in the premises. Let M vary over \mathbf{T} -models of Γ . We define:

- $\Sigma^0 = \{M \mid M \models \Gamma\}$.
- Where $0 < i \leq n$, a minimal Dab^i -consequence of Γ is a (set-theoretically) shortest Dab^i -formula that is true in all $M \in \Sigma^{i-1}$.
- Where $0 < i \leq n$, and $Dab^i(\Delta_1)$, $Dab^i(\Delta_2)$, ... are the minimal Dab^i -consequences of Γ , $U^i(\Gamma) = \Delta_1 \cup \Delta_2 \cup \dots$
- $Ab^i(M) = \{A \in \Omega^i \mid M \models A\}$
- Where $0 < i \leq n$, $\Sigma^i = \{M \in \Sigma^{i-1} \mid Ab^i(M) \subseteq U^i(\Gamma)\}$.
- The Reliable models (\mathbf{T}^{sr} -models) of Γ are the members of Σ^n .

We proceed analogously for Minimal Abnormality, but here the matter is simpler. We define:

- $\Sigma^0 = \{M \mid M \models \Gamma\}$.
- $Ab^i(M) = \{A \in \Omega^i \mid M \models A\}$
- Where $0 < i \leq n$, $\Sigma^i = \{M \in \Sigma^{i-1} \mid \text{for no } M' \in \Sigma^{i-1}, Ab^i(M') \subset Ab^i(M)\}$.
- The Minimal Abnormal models (\mathbf{T}^{sm} -models) of Γ are the members of Σ^n .

$\Gamma \models_{\mathbf{T}^{sr}} A$ iff A is verified by all reliable models of Γ . $\Gamma \models_{\mathbf{T}^{sm}} A$ iff A is verified by all minimally abnormal models of Γ . It is provable that both logics are sound and complete with respect to their semantics.

I still have to combine the adaptive logics of inductive generalization from Section 3 with the prioritized adaptive logics from the present section. As few applications will justify that one combines Reliability for one logic with Minimal Abnormality for the other, two combinations seem most attractive.

As before, the set of (original and new) premises Γ will consist solely of non-modal formulas and of formulas of the form $\diamond^i \sim (\exists A \wedge \exists \sim A)$, and I suppose that all $i \leq n$ for some n . The logic we are after is obtained by combining flat adaptive logics. Let the combination for Reliability be called \mathbf{ILp}^r . What we want is¹⁶

$$Cn_{\mathbf{ILp}^r}(\Gamma) = Cn_{\mathbf{IL}}(Cn_{\mathbf{T}^{sr}}(\Gamma)). \quad (7)$$

This may be spelled out as follows:

$$Cn_{\mathbf{ILp}^r}(\Gamma) = Cn_{\mathbf{IL}}(Cn_{\mathbf{T}_n^{sr}}(Cn_{\mathbf{T}_{n-1}^{sr}}(\dots(Cn_{\mathbf{T}_1^{sr}}(\Gamma))\dots))) \quad (8)$$

which makes it transparent that first all premises of the form $\diamond^i(A \wedge \sim A)$ are taken into account, starting with $i = 1$, and next the result is interpreted as normal as possible with respect to \mathbf{IL} -abnormalities. The situation is similar for the Minimal Abnormality combination, \mathbf{ILp}^m . We want

$$Cn_{\mathbf{ILp}^m}(\Gamma) = Cn_{\mathbf{IL}}(Cn_{\mathbf{T}^{sm}}(\Gamma)). \quad (9)$$

In order to avoid confusion, let us rename the Ω from Section 3 to Ω^ω —so $\Omega^\omega = \{\exists A \wedge \exists \sim A \mid A \in \mathcal{F}^\circ\}$.

The combined adaptive logics \mathbf{IL}^r and \mathbf{IL}^m are defined by the lower limit logic \mathbf{T} , the sets of abnormalities $\Omega^1, \Omega^2, \dots, \Omega^\omega$, and the Reliability strategy and

¹⁶There is some notational abuse as $Cn_{\mathbf{IL}}(\Gamma)$ is not defined for \mathcal{L}^M , but the idea is clear and \mathbf{ILp}^r is correctly defined below.

the Minimal Abnormality Strategy respectively. Incidentally, the upper limit logic is **UCL** extended with **Triv**.

Let us move to the dynamic proofs. Let $Dab(\Theta)$ refer to the disjunction of a $\Theta \subseteq \Omega^1 \cup \Omega^2 \cup \dots \cup \Omega^\omega$. The inference rules for the combined adaptive logic are exactly like those of **IL**, except that **CL** should be replaced by **T**.

The marking definitions too are easily obtained in view of (8). Where $i \geq 1$, let $Dab^i(\Delta)$ be as before in this section— $Dab^\omega(\Delta)$ denotes the disjunction of the members of $\Delta \subseteq \Omega^\omega$. $Dab^\omega(\Delta)$ is a minimal Dab^ω -formula at stage s of a proof iff, at stage s , $Dab^\omega(\Delta)$ is the second element of an unmarked line that has some $\Theta \subseteq \Omega^1 \cup \Omega^2 \cup \dots$ as its fifth element—again, the order in which lines are marked will be essential. $U_s^\omega(\Gamma)$ is defined from the minimal Dab^ω -formulas at stage s just as $U_s(\Gamma)$ was defined in Section 3 from (what was there called) the minimal Dab -formulas at stage s . $\Phi_s^\omega(\Gamma)$ is defined from the minimal Dab^ω -formulas at stage s just as $\Phi_s(\Gamma)$ is defined in Section 3 from (what is there called) the minimal Dab -formulas at stage s .

Given a proof at a stage, the Definitions 6 and 7 are adjusted in such a way that the lines are first marked in view of level 1, next in view of level 2, and so on up to the highest level n —I supposed that there was one—and finally in view of level ω .

The semantics is completely standard and is left to the reader. All one has to remember is that the selection of the **T**-models of Γ is defined from, first, a selection in view of Ω^1 , next a selection in view of Ω^2 , and so on up to Ω^n , and finally a selection in view of Ω^ω .

9 An Example

Let us consider an example of a premise set. My main aim here is to illustrate **IL** as well as the way in which applying it provides insights in the generalizations that are compatible with the data, and evokes certain questions that may be answered by tests or by defeasible conjectures.

Let the premise set be

$$\Gamma = \{Pa \wedge \sim Qa \wedge \sim Ra, \sim Pb \wedge Qb \wedge Rb, Pc \wedge Rc, Qd \wedge \sim Pe, Sf \wedge \sim Sg\}.$$

For typographical reasons I abbreviate an abnormality $\exists A \wedge \exists \sim A$ as A in the condition as well as in Dab -formulas. I also write continuous conjunctions where there is no ambiguity. As far as the lines derived in the example are concerned, it does not make any difference whether the proof proceeds in terms of **IL^T** or **IL^m**; the same lines will be marked or unmarked at the same stage—of course it is easiest to read the proof in terms of **IL^T**. For the sake of transparency, I add to each mark the number of the stage at which it is introduced.

1	$Pa \wedge \sim Qa \wedge \sim Ra$	PREM	\emptyset
2	$\sim Pb \wedge Qb \wedge Rb$	PREM	\emptyset
3	$Pc \wedge Rc$	PREM	\emptyset
4	$Qd \wedge \sim Pe$	PREM	\emptyset
5	$Sf \wedge \sim Sg$	PREM	\emptyset
6	$\forall x(Qx \supset Rx)$	2; RC	$\{Qx \supset Rx\}$
7	Rd	4, 6; RU	$\{Qx \supset Rx\}$
8	$\forall x(\sim Px \supset Qx)$	2; RC	$\{\sim Px \supset Qx\}$

9	Qe	4, 8; RU	$\{\sim Px \supset Qx\}$
10	Re	6, 9; RU	$\{Qx \supset Rx, \sim Px \supset Qx\}$
11	$\forall x(\sim Px \supset Rx)$	6, 8; RU	$\{Qx \supset Rx, \sim Px \supset Qx\}$

It is also possible to derive the formula of line 11 in a direct way by the conditional rule:

12	$\forall x(\sim Px \supset Rx)$	2; RC	$\{\sim Px \supset Rx\}$
----	---------------------------------	-------	--------------------------

If line 6 or line 8 is marked, line 11 is also marked, but line 12 may still be unmarked. This nicely illustrates that a generalization that is a **CL**-consequence of other derived generalizations need not be rejected if one of those from which it is a **CL**-consequence are rejected. **IL** warrants, however, that if $\forall A$ is a **CL**-consequence of other generalizations, and $\forall A$ is rejected, then one of the generalizations from which it is **CL**-derived is also rejected. The inductive prediction Re , here derived in line 10, may also be derived from lines 4 and 11 (with the same condition as line 11, which is the condition of line 10) or from lines 4 and 12 (with the same condition as line 12). It is easily seen that no line so far in this proof will be marked in any extension of the proof provided no new premises are added.

13 ^{√14}	$\forall x(Px \supset \sim Rx)$	1; RC	$\{Px \supset \sim Rx\}$
14	$Dab(Px \supset \sim Rx)$	1, 3; RU	\emptyset

The generalization $\forall x(Px \supset \sim Rx)$ is falsified by the premise of line 3. As also an instance of $\forall x(Px \supset \sim Rx)$ occurs in the premises, for example in line 1, line 14 is derivable and line 13 is marked.¹⁷ Obviously line 13 will remain marked in any extension of the proof. No new data and no conjectures can possibly remove the mark.

Here is an interesting further extension of the proof:

15 ^{√21}	$\forall x(Px \supset \sim Qx)$	1; RC	$\{Px \supset \sim Qx\}$
16 ^{√21}	$\sim Qc$	3, 15; RU	$\{Px \supset \sim Qx\}$
17 ^{√21}	$\forall x(Rx \supset Qx)$	2; RC	$\{Rx \supset Qx\}$
18 ^{√21}	Qc	3, 17; RU	$\{Rx \supset Qx\}$
19	$\exists x\sim(Px \supset \sim Qx) \vee \exists x\sim(Rx \supset Qx)$	3; RU	\emptyset
20	$\exists x(Px \supset \sim Qx) \wedge \exists x(Rx \supset Qx)$	1, 2; RU	\emptyset
21	$Dab\{Px \supset \sim Qx, Rx \supset Qx\}$	19, 20; RU	\emptyset
22 ^{√26}	$\forall x(Px \supset Sx)$	4; RC	$\{Px \supset Sx\}$
23 ^{√26}	Sa	1, 22; RU	$\{Px \supset Sx\}$
24	$\exists x\sim(Px \supset Sx) \vee \exists x\sim(Px \supset \sim Sx)$	3; RU	\emptyset
25	$\exists x(Px \supset Sx) \wedge \exists x(Px \supset \sim Sx)$	4; RU	\emptyset
26	$Dab\{Px \supset Sx, Px \supset \sim Sx\}$	24, 25; RU	\emptyset

Remark that $\forall x(Rx \supset Qx)$ and $\forall x(Px \supset \sim Qx)$ are both compatible with the data, but that there is no reason to prefer the one over the other in view of the data. Similarly for $\forall x(Px \supset Sx)$ and $\forall x(Px \supset \sim Sx)$ —the latter is not derived in the proof, but if can be derived on the condition $\{Px \supset \sim Sx\}$,

¹⁷If no instance of $\forall x(Px \supset \sim Rx)$ occurred in the premises, $\forall x(Px \supset \sim Rx)$ would not be derivable in the first place. All one could derive on the condition $\{Px \supset \sim Rx\}$ would be $\forall x(Px \supset \sim Rx) \vee \forall x\sim(Px \supset \sim Rx)$.

from line 4 (and both generalizations can also be derived on their respective conditions from line 5).

Lines 21 and 26 suggest the questions that, if suitably answered, may still lead to the derivability of one of the competing generalizations—of course, certain answers may reveal both generalizations to be false (in each of the two cases). As explained in previous sections, tests may be available to answer the questions. In view of the data, the question evoked by line 21 implies $\{Qc, \sim Qc\}$ and, if this can be settled by empirical means, it constitutes the most obvious test to settle the matter. Indeed, one of the generalizations will at once be falsified by any answer to the question.

The most obvious tests, if they are tests, derivable from the question evoked by line 26 are obviously $\{Sa, \sim Sa\}$ and $\{Sc, \sim Sc\}$. Of course, one might also try $\{Pf, \sim Pf\}$ and $\{Pg, \sim Pg\}$, but if one obtains the answer $\sim Pf$ (respectively $\sim Pg$) to these, nothing is decided.¹⁸

Suppose that $\{Qc, \sim Qc\}$ is a test, that it is performed and that the obtained answer is $\sim Qc$. The proof then continues as follows (I repeat some lines because their marks change):

15	$\forall x(Px \supset \sim Qx)$	1; RC	$\{Px \supset \sim Qx\}$
16	$\sim Qc$	3, 15; RU	$\{Px \supset \sim Qx\}$
17 ^{√21}	$\forall x(Rx \supset Qx)$	2; RC	$\{Rx \supset Qx\}$
18 ^{√21}	Qc	3, 17; RU	$\{Rx \supset Qx\}$
19	$\exists x \sim (Px \supset \sim Qx) \vee \exists x \sim (Rx \supset Qx)$	3; RU	\emptyset
20	$\exists x(Px \supset \sim Qx) \wedge \exists x(Rx \supset Qx)$	1, 2; RU	\emptyset
21	$Dab\{Px \supset \sim Qx, Rx \supset Qx\}$	19, 20; RU	\emptyset
⋮			
27	$\sim Qc$	New Prem	\emptyset
28	$\exists x(Rx \supset Qx) \wedge \exists x \sim (Rx \supset Qx)$	2, 3, 27; RU	\emptyset

In view of the presence of line 28, which may be abbreviated as $Dab\{Px \supset \sim Qx\}$, the formula of line 21 is not a minimal *Dab*-formula from stage 28 on, and hence lines 17 and 18 are unmarked from that stage on.

If no test enables one to answer the question evoked by line 21, the researcher may introduce a conjecture, say $\diamond\diamond\sim(\exists x(Px \supset \sim Qx) \wedge \exists x \sim (Px \supset \sim Qx))$, which I shall have to abbreviate as $\diamond\diamond\sim(Dab^\omega(Px \supset \sim Qx))$ for typographical reasons. Let $!^2!^\omega(Px \supset \sim Qx)$ abbreviate

$$(\exists x(Px \supset \sim Qx) \wedge \exists x \sim (Px \supset \sim Qx)) \wedge \diamond\diamond\sim(\exists x(Px \supset \sim Qx) \wedge \exists x \sim (Px \supset \sim Qx))$$

The proof may then be continued as follows:

15	$\forall x(Px \supset \sim Qx)$	1; RC	$\{Px \supset \sim Qx\}$
16	$\sim Qc$	3, 15; RU	$\{Px \supset \sim Qx\}$
17 ^{√21}	$\forall x(Rx \supset Qx)$	2; RC	$\{Rx \supset Qx\}$
18 ^{√21}	Qc	3, 17; RU	$\{Rx \supset Qx\}$
19	$\exists x \sim (Px \supset \sim Qx) \vee \exists x \sim (Rx \supset Qx)$	3; RU	\emptyset
20	$\exists x(Px \supset \sim Qx) \wedge \exists x(Rx \supset Qx)$	1, 2; RU	\emptyset

¹⁸According to [13] and [12], the questions $\{Pf, \sim Pf\}$ and $\{Pg, \sim Pg\}$ are not erotetically implied by the main question, precisely because some direct answers to them do not narrow down the direct answers to the main question.

21	$Dab\{Px \supset \sim Qx, Rx \supset Qx\}$	19, 20; RU	\emptyset
\vdots			
27'	$\diamond\diamond\sim(Dab^\omega(Px \supset \sim Qx))$	Conj	\emptyset
28'	$\sim(Dab^\omega(Px \supset \sim Qx))$	27'; RC	$\{!^{2!^\omega}(Px \supset \sim Qx)\}$
29'	$\exists x(Rx \supset Qx) \wedge \exists x\sim(Rx \supset Qx)$	21, 28'; RU	$\{!^{2!^\omega}(Px \supset \sim Qx)\}$

The effect of a conjecture should not be the same as the effect of a test and, unlike what the two extensions of the proof 1–26 suggest, it is not. This is easily seen by considering the case where new data falsify $\forall x(Px \supset \sim Qx)$. Suppose that, for whatever reason, one obtains the further information $Pf \wedge Qf$. Let us add this new premise to both extensions considered, and see what happens. First consider the extension that resulted from the test:

15 $\sqrt{30}$	$\forall x(Px \supset \sim Qx)$	1; RC	$\{Px \supset \sim Qx\}$
16 $\sqrt{30}$	$\sim Qc$	3, 15; RU	$\{Px \supset \sim Qx\}$
17 $\sqrt{21}$	$\forall x(Rx \supset Qx)$	2; RC	$\{Rx \supset Qx\}$
18 $\sqrt{21}$	Qc	3, 17; RU	$\{Rx \supset Qx\}$
19	$\exists x\sim(Px \supset \sim Qx) \vee \exists x\sim(Rx \supset Qx)$	3; RU	\emptyset
20	$\exists x(Px \supset \sim Qx) \wedge \exists x(Rx \supset Qx)$	1, 2; RU	\emptyset
21	$Dab\{Px \supset \sim Qx, Rx \supset Qx\}$	19, 20; RU	\emptyset
\vdots			
27	$\sim Qc$	New Prem	\emptyset
28	$\exists x(Rx \supset Qx) \wedge \exists x\sim(Rx \supset Qx)$	2, 3, 27; RU	\emptyset
29	$Pf \wedge Qf$	New Prem	\emptyset
30	$\exists x(Px \supset \sim Qx) \wedge \exists x\sim(Px \supset \sim Qx)$	1, 29; RU	\emptyset

In this case, both generalizations are rejected in view of new evidence, and so are the inductive predictions on lines 16 and 18. Of course the inductive prediction of line 16 is true, as appears from line 27, but it still was not a correct inductive prediction because the generalization required for deriving it from Pc is false.

Let us now add the new information $Pf \wedge Qf$ to the extension of 1–26 that was obtained by the conjecture:

15 $\sqrt{31'}$	$\forall x(Px \supset \sim Qx)$	1; RC	$\{Px \supset \sim Qx\}$
16 $\sqrt{31'}$	$\sim Qc$	3, 15; RU	$\{Px \supset \sim Qx\}$
17	$\forall x(Rx \supset Qx)$	2; RC	$\{Rx \supset Qx\}$
18	Qc	3, 17; RU	$\{Rx \supset Qx\}$
19	$\exists x\sim(Px \supset \sim Qx) \vee \exists x\sim(Rx \supset Qx)$	3; RU	\emptyset
20	$\exists x(Px \supset \sim Qx) \wedge \exists x(Rx \supset Qx)$	1, 2; RU	\emptyset
21	$Dab\{Px \supset \sim Qx, Rx \supset Qx\}$	19, 20; RU	\emptyset
\vdots			
27'	$\diamond\diamond\sim(Dab^\omega(Px \supset \sim Qx))$	Conj	\emptyset
28' $\sqrt{32'}$	$\sim(Dab^\omega(Px \supset \sim Qx))$	27'; RC	$\{!^{2!^\omega}(Px \supset \sim Qx)\}$
29' $\sqrt{32'}$	$\exists x(Rx \supset Qx) \wedge \exists x\sim(Rx \supset Qx)$	21, 28'; RU	$\{!^{2!^\omega}(Px \supset \sim Qx)\}$
30'	$Pf \wedge Qf$	New Prem	\emptyset
31'	$\exists x(Px \supset \sim Qx) \wedge \exists x\sim(Px \supset \sim Qx)$	1, 30'; RU	\emptyset
32'	$!^{2!^\omega}(Px \supset \sim Qx)$	27', 31'; RU	\emptyset

In this case, $\forall x(Px \supset \sim Qx)$ has to be rejected, but, as there are no empirical reasons to reject $\forall x(Rx \supset Qx)$, this generalization becomes finally **IL**-derivable (with respect to the present data). Remark that here the formula of line 21 is not a minimal *Dab*-formula in view of line 31'. But unlike what was the case in the previous extension (the one leading up to line 30), $\exists x(Px \supset \sim Qx) \wedge \exists x \sim(Px \supset \sim Qx)$ is not **CL**-derivable from the premises and hence lines 17 and 18 are unmarked.

10 Guesses

A different kind of ‘conjectures’, I shall call them *guesses*, are not evoked by minimal *Dab*-formulas, but express, with more or less priority, certain convictions that a researcher may have. These may derive from his or her world-view or from some other theoretical positions, in general from personal constraints.

In actual science, guesses clearly play a role. They are responsible for the fact that one research group tries out one road, whereas another research group tries out a very different one. So it should be possible to give them a role in the present framework. This is easily done, provided it is done with some care.

The general idea is that guesses are introduced as prioritized premises, whence they are in principle defeasible—see below. No specific form need to be imposed on them: a guess may be a generalization, an existential statement, or whatever. This has two important consequences. First, if the priorities are handled in terms of **T**, as in Section 8, then all **CL**-consequences of a guess have at least the priority of the guess itself. This is sometimes desirable, but not always. Thus if the guess is a generalization that was introduced because it was seen as expressing a deep-structure law, and the generalization turns out to be falsified, one will not want to retain its consequences, for example its instances. So one should handle the logic that governs the priorities with great care, and obviously different such logics may be invoked for different guesses—see [6] for several such logics.

The second remark concerns the status of the guess as a premise. Once introduced, the conjectures from Section 8 were not revised themselves. I mean that a statement of the form $\diamond^i \sim(\exists A \wedge \exists \sim A)$ is never removed and is never replaced by a statement of the same form but with a different value of i . The data determine whether the conjecture has any effect, that is, whether it is defeated or not—if it is defeated $\sim \exists A \wedge \exists \sim A$ is not derivable, but even then the premise $\diamond^i \sim(\exists A \wedge \exists \sim A)$ itself is left untouched.

It seems to me that *guesses* should be handled in a different way. The justification for accepting them with a certain priority does not depend on the **IL**-proof; the question whether they are true is even not evoked by it. As the researcher may be working on different problems at the same time, may obtain new information, or may for other reasons change his or her personal constraints, it seems reasonable that guesses and their priorities are revised without anything in the proof requiring this. Technically this may be realized by allowing one to delete a guess from the proof, together with all lines that have the guess in their path. Possibly, the same guess may be introduced (at the end of the proof) with a different priority.

However, a further qualification is required, viz. that sometimes the proof itself may convince one to remove a guess. Suppose indeed that a guess of the

form $\exists x(Px \wedge \sim Qx)$ prevents $\forall(Px \supset Qx)$ from being derived, but that it turns out that $\forall(Px \supset Qx)$ is the only generalization (among some competitors) that is compatible with the data and is **IL**-derivable, except that the effect of the guess prevents this. Suppose even that new data were obtained, which specify the Q -hood of some more P s, and that all these data concern P s that are Q . It seems then reasonable to give up the guess—in practice more considerations may obviously be involved.

11 In Conclusion

Apart from the clarification provided by the BS rule, the main importance of the previous results seems to be twofold. First, **IL** leads to a very sensible analysis of inductive generalization (and predictions derived from generalizations). In this sense it is better than the considered truisms. Moreover, the special cases we have met illustrate where the truisms derive from.

A second important set of results concerns the fact that *application* of **IL** to a set of data, possibly in the presence of background knowledge, evokes questions which may be answered by tests or by conjectures (in the sense of Section 7). Thus applying **IL** according to the procedure guides one to gather certain empirical data, viz. to make certain observations or to set up certain experiments. It also guides one to rely on one's theoretical insights and background knowledge in order to narrow down the set of suspect abnormalities. This will lead to more generalizations and predictions. These in turn will interfere to evoke more questions, which will suggest further tests or further conjectures. At the same time, these tests may lead to the rejection of certain previously introduced conjectures (in that they may prevent $\diamond^i \sim(\exists A \wedge \exists \sim A)$ from leading to $\sim(\exists A \wedge \exists \sim A)$). All this shows that **IL** does not merely determine which generalizations are acceptable in view of a set of data, but moreover provides a guide for both empirical and theoretical research in the domain of investigation.

I stressed that the *application* of **IL** has this effect. What I meant was of course the application of the procedure referred to in Section 6. Derived generalizations and their contextual consequences (predictions) may lead to contradictions, which reveal that some of the derived items are not finally derivable. But even if no problem is revealed in this way, trying to establish that a generalization or a prediction relying on a generalization is finally derived in view of the present data, leads to new questions, and hence to new data and new conjectures.

References

- [1] Diderik Batens. Inconsistency-adaptive logics. In Ewa Orłowska, editor, *Logic at Work. Essays Dedicated to the Memory of Helena Rasiowa*, pages 445–472. Physica Verlag (Springer), Heidelberg, New York, 1999.
- [2] Diderik Batens. A general characterization of adaptive logics. *Logique et Analyse*, 173–175:45–68, 2001. Appeared 2003.
- [3] Diderik Batens. On a partial decision method for dynamic proofs. In Hendrik Decker, Jørgen Villadsen, and Toshiharu Waragai, editors,

PCL 2002. Paraconsistent Computational Logic, pages 91–108. (= *Data-logiske Skrifter* vol. 95), 2002. Also available as cs.LO/0207090 at <http://arxiv.org/archive/cs/intro.html>.

- [4] Diderik Batens. On a logic of induction. In Roberto Festa, Atocha Aliseda, and Jeanne Peijnenburg, editors, *Confirmation, Empirical Progress, and Truth Approximation. Essays in Debate with Theo Kuipers*, Poznan Studies in the Philosophy of the Sciences and the Humanities. Rodopi, Amsterdam, in print.
- [5] Diderik Batens. Narrowing down suspicion in inconsistent premise sets. To appear in the *Festschrift* for Jerzy Perzanowski.
- [6] Diderik Batens and Lieven Haesaert. On classical adaptive logics of induction. *Logique et Analyse*, 173–175:255–290, 2001. Appeared 2003.
- [7] Diderik Batens and Joke Meheus. Shortcuts and dynamic marking in the tableau method for adaptive logics. *Studia Logica*, 69:221–248, 2001.
- [8] Diderik Batens, Joke Meheus, Dagmar Provijn, and Liza Verhoeven. Some adaptive logics for diagnosis. *Logic and Logical Philosophy*, 11/12:39–65, 2003.
- [9] Rudolf Carnap. *The Continuum of Inductive Methods*. University of Chicago Press, Chicago, 1952.
- [10] Karl R. Popper. *Logik der Forschung*. Verlag von Julius Springer, Wien, 1935. English translation, with new appendices, [11].
- [11] Karl R. Popper. *Logic of Scientific Discovery*. Hutchinson, London, 1959. English translation, with new appendices of [10].
- [12] Andrzej Wiśniewski. *The Posing of Questions. Logical Foundations of Erotetic Inferences*. Kluwer, Dordrecht, 1995.
- [13] Andrzej Wiśniewski. The logic of questions as a theory of erotetic arguments. *Synthese*, 109:1–25, 1996.